



## APOLLO NON-INTEGRATED LUG & APOLLO LITE/Ti Thread Tenon

This tenon drawing is provided only as a setup guideline at minimum cartridge SAMMI specification. It is the sole responsibility of a qualified gunsmith to verify all dimensions in order to allow for proper clearances.

Tenon length only valid when using included surface-ground .250" recoil lug.  
Use of other lugs will require altering of these dimensions.

Chamber chamfer  
Approx .010" x 45°

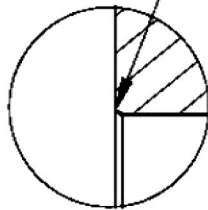

DETAIL B  
SCALE 4:1

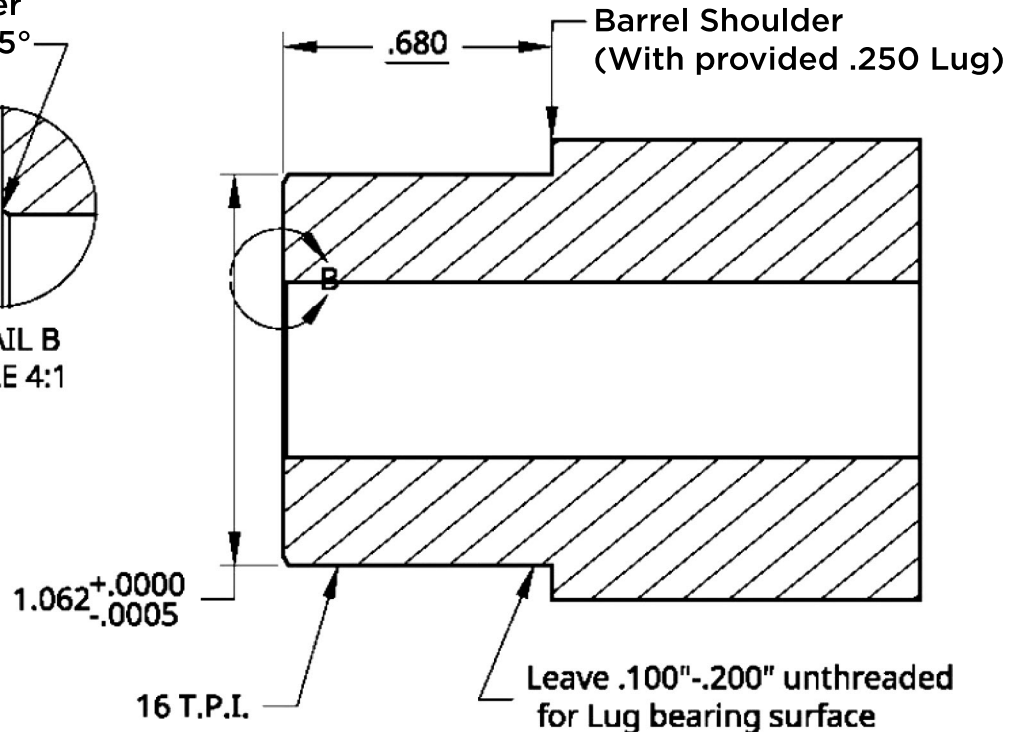

Headspace Tolerance: .585" +/- .001"

Bolt Face as drawn is .155" from end of tenon.

Tenon Length of 0.680" leaves 0.010" clearance from bolt nose to barrel face.

It is recommended to chamfer mouth of chamber to ease feeding.

0.010" depth with approximately 30° angle is sufficient - user preference.

\*NOTE: Increasing chamber chamfer may aid in feeding but decreases case support at the web.